

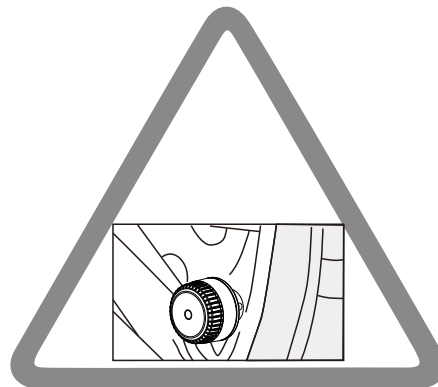

270T

Tire Pressure Monitoring System

- Installation and Operation Manual of External Sensor



I. Contents of accessories



Tire pressure wire



Tire pressure sensor x 4



Upper and lower covers of fixture



Car charging plug



Waterproofing ring / Allen key / one package of screws

II. Install waterproofing ring at sensor

To prevent reducing the service life due to rain, waterproofing ring should be installed in tire pressure sensor, as shown below:

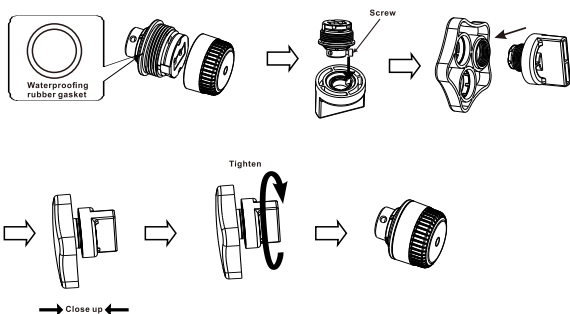

III. Connection way

The terminal of tire pressure wire is connected to TPMS interface, and the other end is connected to car charging plug and put into cigarette lighter (the wiring way is the same as that of car charger).

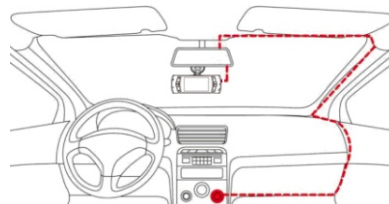

Note: After connecting tire pressure wire, normal working and charging function can be achieved, without the need for connecting with car charger.

IV. TPMS setting and checking

4.1 TPMS setting

Long press key **M** to enter the menu, and then press mode key **⏏** to switch to tire pressure menu, and first select to go to "TPMS setting" for range setting of pressure and temperature

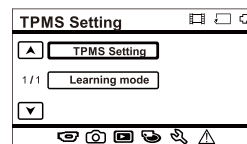

Air pressure units are divided into four kinds (psi, BAR, KPA, Kg/cm2), and temperature units are divided into two kinds (°C, °F)

Tips: The pressure value is generally set at (Max: 50, Min: 20), the temperature is set at 50°C

4.2 TPMS checking

4.2.1 Enter tire pressure learning mode by pressing video key **REC**. The following picture will appear.

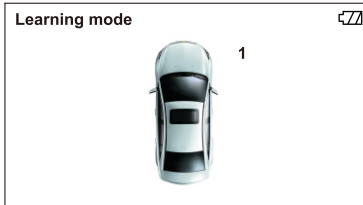

4.2.2 After pressing video key **REC** again, you can hear "beep" from car charger and the blue light of car charger is on. It will keep flashing, indicating that the first calibration has started, waiting for signals sent from tire pressure signal generator.

4.2.3 Remove the dust cap of valve core of tire, and then slowly tighten the sensor (right front) with mark of this tire ; air leakage may occur in a small section, then you will hear "beep", indicating that the right front tire has been calibrated successfully, and LCD will display the calibration data.

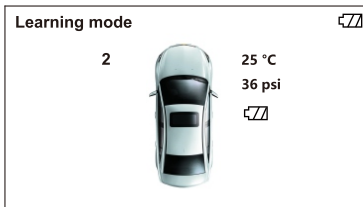

4.2.4 After pressing video key **REC** again, you can hear "beep" from car charger and the blue light of car charger is flashing, indicating that the right front tire calibration starts, waiting for tire pressure signals.

4.2.5 Continue Step 4.2.3, slowly tighten the left front sensor; the left front tire calibration is successful after hearing "beep".

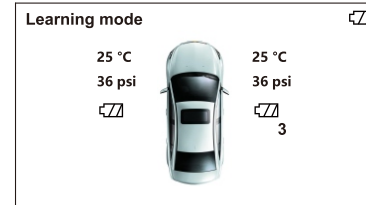

The rest can be done in the same manner to complete the calibration of the four tires, and the following picture will appear.

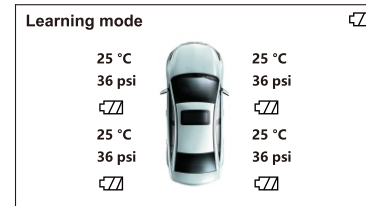

Important note: After completing the calibration of the four tires, you must press video key **REC** again to save data and exit.

V. Use tire pressure monitoring

After completing the calibration, exit the menu after pressing M key, and then press M key again to enter monitoring picture; and then you can see the data that were calibrated just.

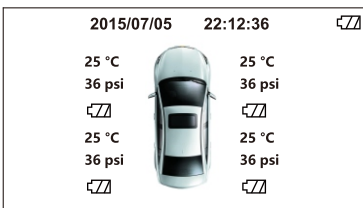

You can use tire pressure monitoring, and you can clearly know the real-time temperature and air pressure value of each tire.

Tips:

1. After the calibration, if you do not see the values that were calibrated just in the monitoring interface, or other values are displayed, please wait for about 10 minutes; and then the calibrated values will be displayed.
2. If it does not return to normal, you need to calibrate it again.

VI. Replace the battery of sensor

When LCD displays the low-power icon of tire , please timely change the flashing sensor battery (lithium battery CR1632, working temperature: -40 + 80 degrees), the user can purchase from the dealer.

1. First remove the sensor from tire, and then unscrew and replace the battery.

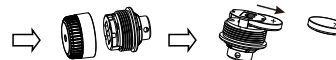
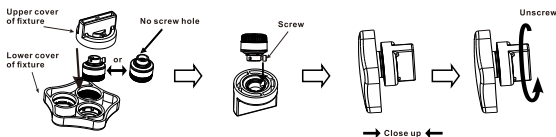

2. Install the new lithium battery CR1632, and make the positive (+) upward.



3. Then tighten the housing, and pay attention not to damage the waterproof ring.

VI. Sensor parameters

Working temperature	-40°C ~80°C
Storage temperature	-40°C ~85°C
Pressure range	0~6 BAR, 0~87psi
Pressure accuracy	±0.1BAR (±1.5psi)
Temperature accuracy	±3°C
Transmitting power	<10dBm
Transmitting frequency	433.92MHz
Service life of battery	3~4 years (CR1632-40~80°C)
Dimensions (L*W*H)	21mm (diameter) 21mm (height)
Weight	9g



C270T 輪胎氣壓監測系統

-----外置感測器安裝使用指南

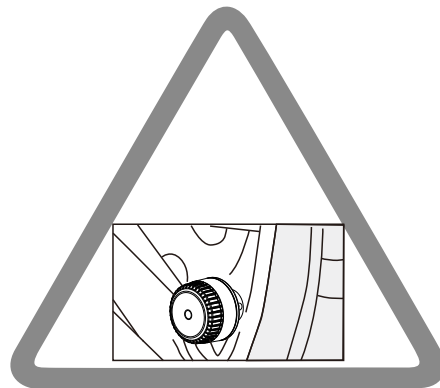

一 配件內容



胎壓線



胎壓感測器x4



夾具上下蓋



車充頭



防水圈/六角匙/螺絲一包

二 在感測器上安裝防水圈

為防止因雨水導致使用壽命減少，需在胎壓感測器上安裝防水圈，圖示如下：

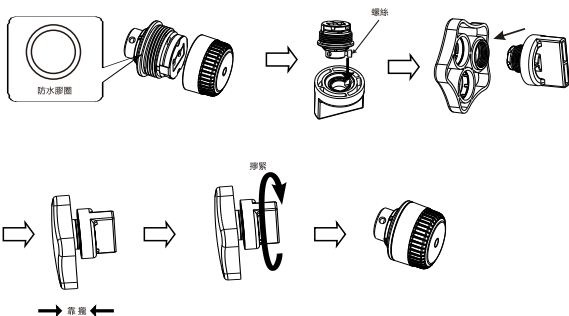

→ 安裝 ←

三 連接方式

胎壓線端子連接TPMS介面，另一頭連接車充頭並放進點煙器（佈線方式同車充）

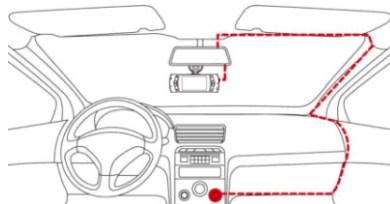

Note：接好胎壓線後，可以正常工作及充電作用，不需要再接車充。

四 TPMS設定及校驗

4.1 TPMS設定

長按 **M** 鍵進入菜單，再按mode鍵  切換到胎壓菜單 ，先選擇到“TPMS設定”進行壓力及溫度的範圍設置。

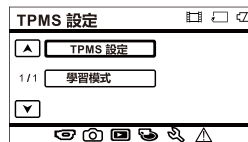

氣壓單位分為4種（psi，BAR，KPA，Kg/cm²）溫度單位分為2種（°C，°F）

溫馨提示：壓力值一般設置為（Max：50，Min：20），溫度設定為50°C

4.2 TPMS校驗

4.2.1 按錄影鍵 **REC** 進入胎壓學習模式，出現以下畫面。

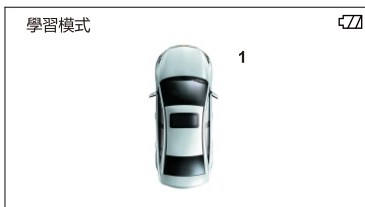

4.2.2 此時再按一次錄影鍵 **REC**，會聽到車充頭髮出“滴”的一聲，且車充頭藍燈會不停的閃爍，表明第一次校正開始，等待胎壓信號發生器發出信號過來。

4.2.3 將輪胎之氣門芯防塵帽取下，再將標註為該輪胎的感測器（右前）慢慢的擰緊，擰的過程中會有一小段漏氣，這個時候會聽到“滴”的一聲，表明右前輪胎校正成功，LCD會顯示校正數據。

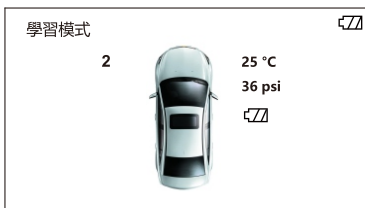

4.2.4 再按一次錄影鍵 **REC**，會聽到車充頭髮出“滴”的一聲，且車充頭藍燈閃爍，表明左前輪胎校正開始，等待胎壓信號過來。

4.2.5 繼續4.2.3步驟，將左前感測器慢慢擰緊，聽到“滴”的一聲，左前輪胎校正成功。

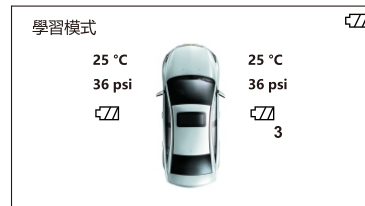

以此類推，校正4個輪胎，出現以下畫面

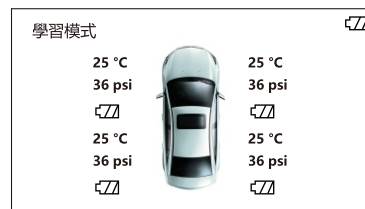

重要提醒：四個胎壓全部校正完成後必須要再次按錄影鍵**REC**保存資料並退出。

五 使用胎壓監控

校正完成後，按M鍵退出功能表，並再次按M鍵進入監控畫面，此時就可以看到剛剛校正資料了。

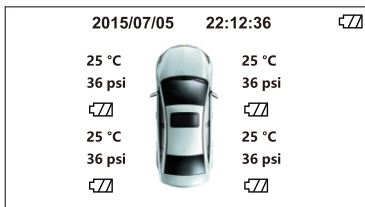

您可以使用胎壓監控了，在行駛過程中可以清楚知道各輪胎即時溫度及氣壓值。

溫馨提示：

1. 校正完，在監控介面如果沒有及時看到剛剛校正的數值，還是顯示其他數值，稍等10秒左右，就會顯示校正數值。
2. 如果沒有恢復正常，需重新再次校正下。

六、感測器更換電池

當LCD顯示輪胎低電圖示  時，請及時更換閃爍的感測器電池（鋰電池CR1632，工作溫度-40+80度），用戶可向經銷商購買。

1. 先將感測器從輪胎中拆下，然後擰開及更換電池

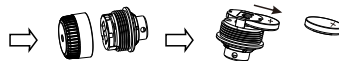
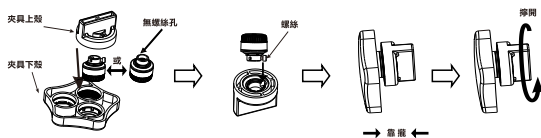

2. 裝上新的鋰電池CR1632，正極（+）朝上。

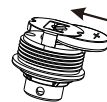

3. 再擰緊外殼，注意防水圈不要損壞。

六 感測器參數

工作溫度	-40°C ~80°C
儲存溫度	-40°C ~85°C
壓力範圍	0~6 BAR, 0~87psi
壓力精確度	±0.1BAR (±1.5psi)
溫度精確度	±3°C
發射功率	<10dBm
發射頻率	433.92MHz
電池壽命	3~4 years (CR1632-40~80°C)
尺寸 (L*W*H)	21mm (diameter) 21mm (height)
重量	9g